

GEISSELE[®]

AUTOMATICS

We Manufacture Confidence[®]

SUPER 42

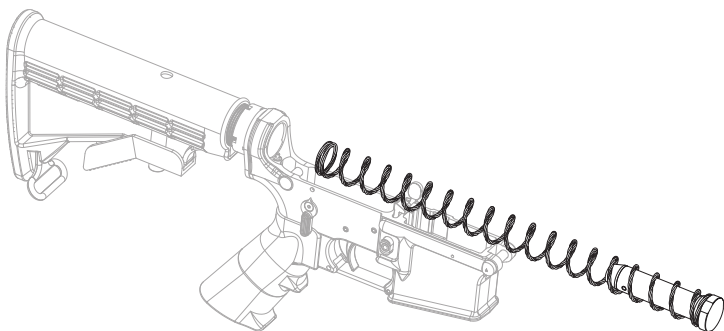

SUPER 42 BRAIDED WIRE BUFFER SPRING AND BUFFER COMBO

Installation Instructions

Part Of Our Enhanced Reliability Package

READ THIS FIRST

Firearm safety is **YOUR** responsibility. You must memorize and put into practice the 4 Rules of Firearm Safety:

- 1. ASSUME EVERY WEAPON IS LOADED.**
- 2. KEEP YOUR FINGER OFF THE TRIGGER UNTIL YOU ARE READY TO SHOOT.**
- 3. DO NOT LET THE MUZZLE POINT AT ANYTHING YOU ARE NOT WILLING TO DESTROY.**
- 4. KNOW YOUR TARGET AND WHAT IS BEYOND.**

INSTALLATION INSTRUCTIONS

The Super 42 spring and Geissele buffer are designed to work together as a set; the spring will not fit over a standard buffer. If installed with a standard buffer damage to the rifle or receiver extension will occur.

SEE PICTURE ABOVE FOR REFERENCE

1. Slide buffer into the Super 42 Spring
2. Thoroughly lubricate buffer spring with a quality firearms lubricant.
3. Hold down buffer retaining pin with a small flat-head screwdriver and slide the buffer/spring combination into the receiver extension.

PRODUCT DESCRIPTION

The Geissele Super 42 Spring was designed to improve the function and reliability of your AR-15 pattern rifle. Its unique spring design uses three independent strands of wire, just like the German MG42 Machine Gun. This concept acts as a harmonic damper and energy absorber by allowing the springs to flex separately from each other. This flex helps displace excess energy which decreases the chance of spring failure and assists with making your AR-15 more reliable.

Compared to the stock spring, The Geissele Super 42 Spring has a decreased tendency to lose length and force over a given round count. As an added bonus, it removes the annoying spring reverberations (twang) heard and felt by the shooter through the buttstock.

The Super 42 Spring has a 15% stronger average return force than the standard buffer spring. This will assist in stripping rounds out of the magazine when operating with a dirty weapon or when using steel-case ammo.

Geissele is also offering replacement buffer weights to give the end user adjustability in their weapon system. With this combination the rifleman can tune their rifle to compensate for a short barrel, overgassed system, suppressed, or other less manageable situations.

COMPATIBILITY AND TUNING

The Geissele Super 42 Spring and Buffer Combination ships in the standard H1 configuration. This is how the M4 Carbine is equipped in the military and it is Geissele's belief that lighter-weight buffers were a cost savings solution to prevent supplying expensive tungsten weights. The H1 and Braided Wire Spring works well in 18" SPRs, 16" rifles with mid-length or carbine gas systems and some 14.5" rifles. Most 14.5" rifles would benefit from the H2 Buffer, which the military issues in their M4A1 rifles. Weapons with barrels shorter than 14.5" will need some testing with H2 or H3 buffer combinations to proof out which is most reliable.

When shooting 300 Blackout with Subsonic ammunition the Super 42 Spring may be too powerful and not allow the rifle to function properly.

Thank You For Your Purchase.

Contact Geissele Automatics with any questions.

GEISSELE AUTOMATICS • 800 NORTH WALES RD • NORTH WALES, PA 19454

TEL: 610-272-2060 | FAX: 610-272-2069

E-MAIL: INFO@GEISSELE.COM | WEB: WWW.GEISSELE.COM

GEISSELE AUTOMATICS SUPER 42 SPRING COMBO - 04/19/16